

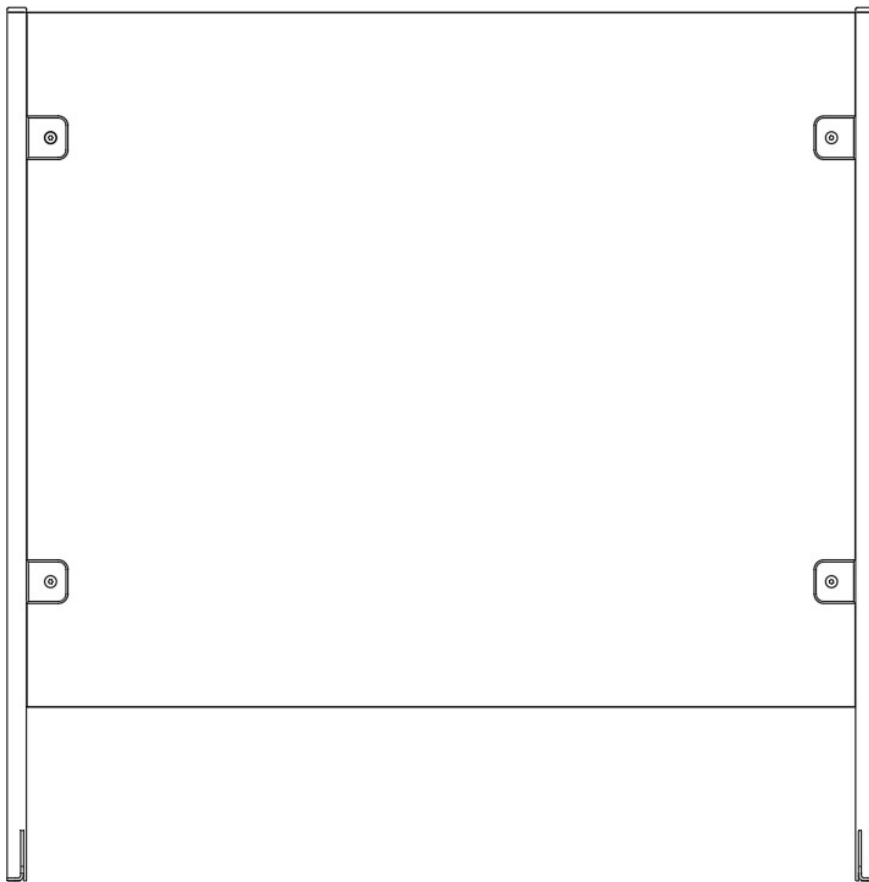

HAHN Lamellen



Hygiene-Spuck-Schutzwand

► Typ 3 ◀

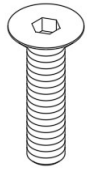

4x (T8)



2x (T9)



8x (T10)

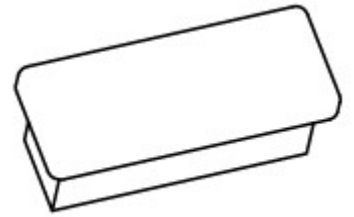

2x (T7)



1x (T11)

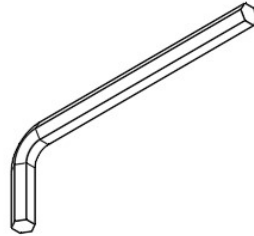

1x (T12)

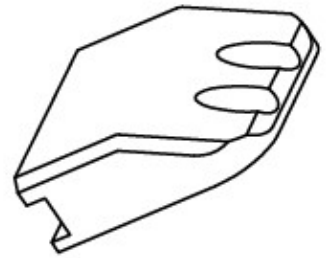

4x (T6)

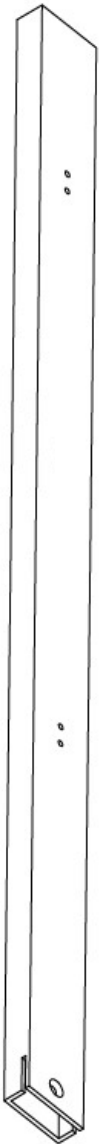

2x (T1)



1x (T4)

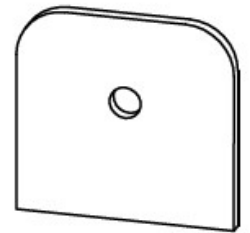

8x (T3)

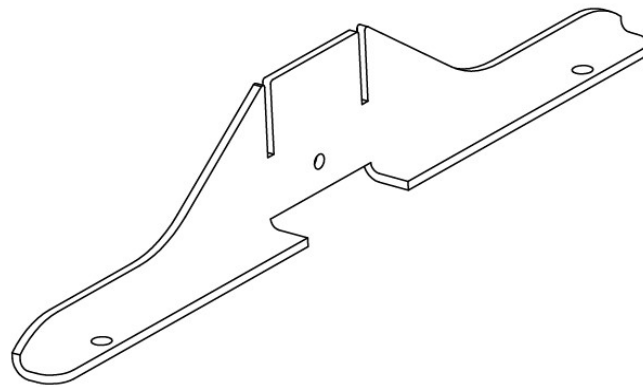

2x (T2)

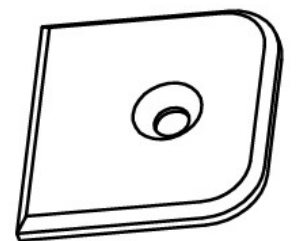

4x (T5)

1.

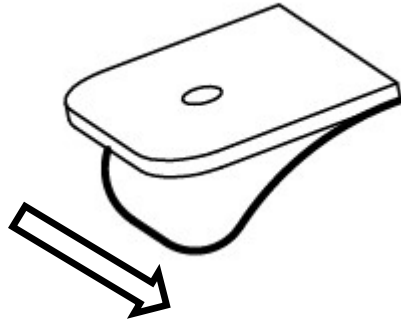

8x (T3)

2.

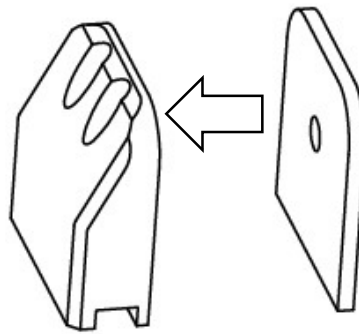

4x (T6 + T3)

3.

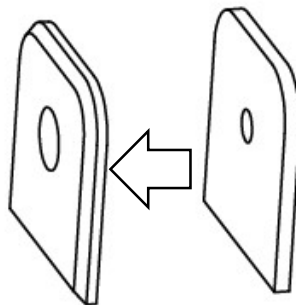

4x (T5 + T3)

4.

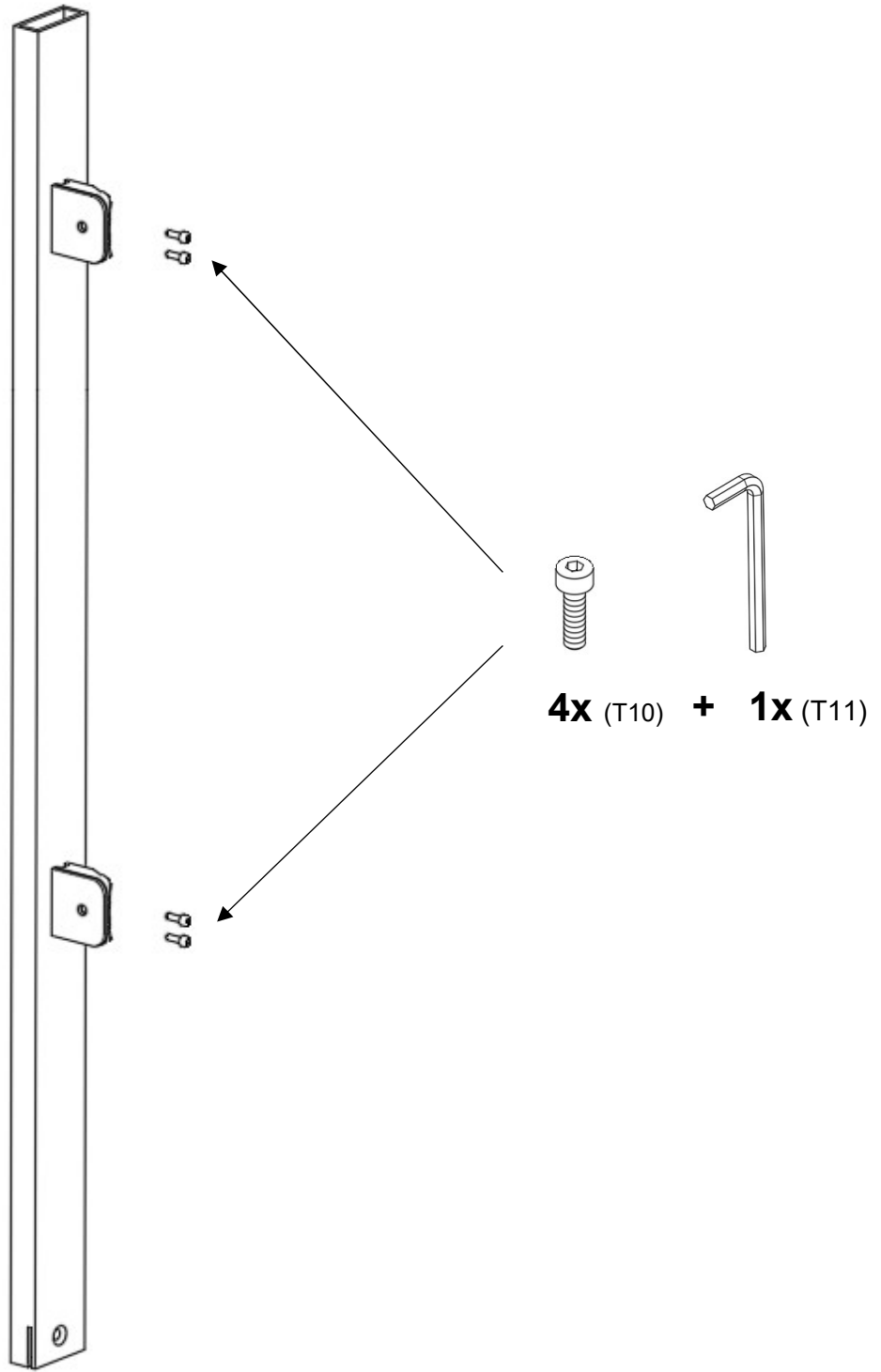

1x (T1, 4xT10, 2xT6, 2xT3)

5.

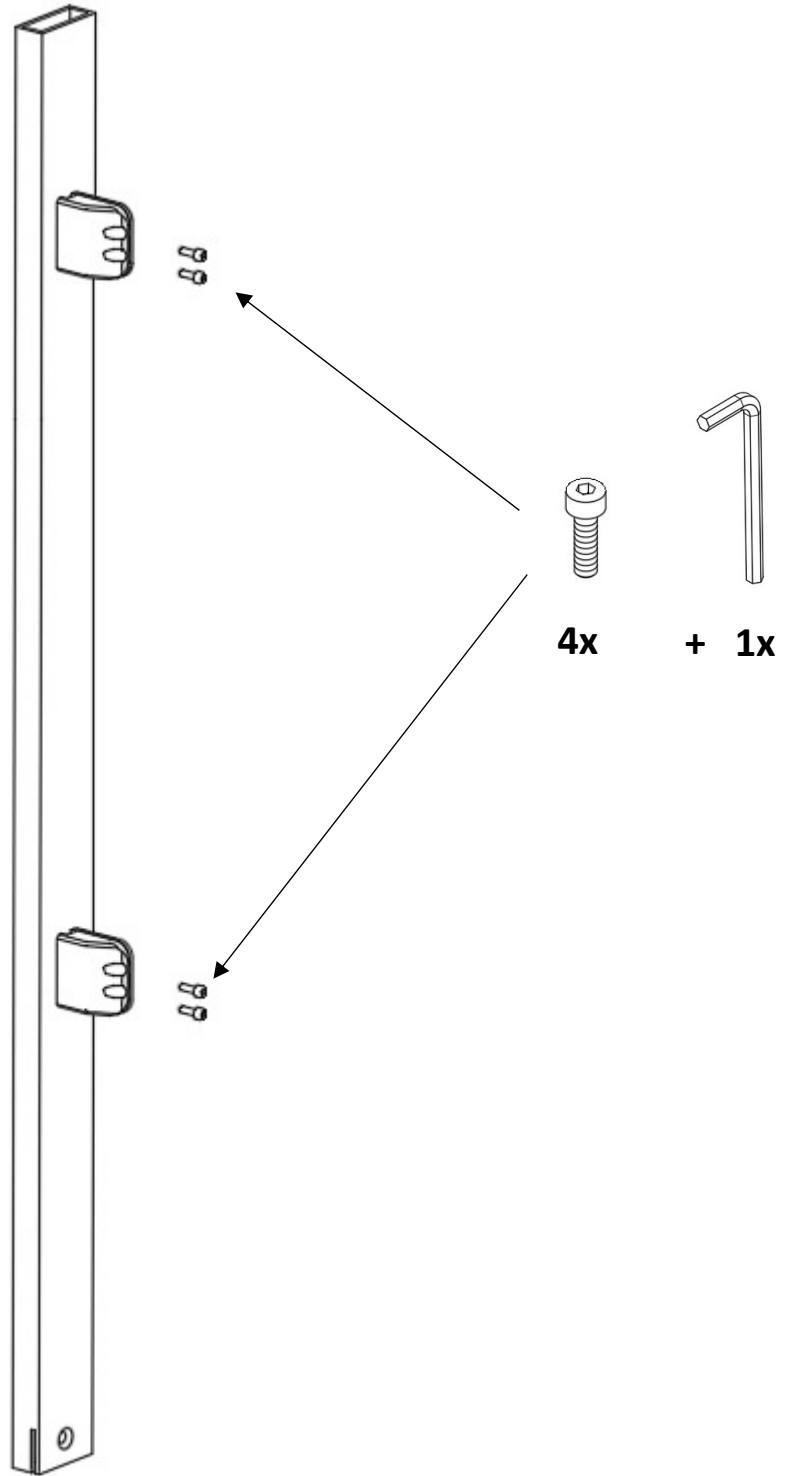

1x (T1, 4xT10, 2xT6, 2xT3)

6.

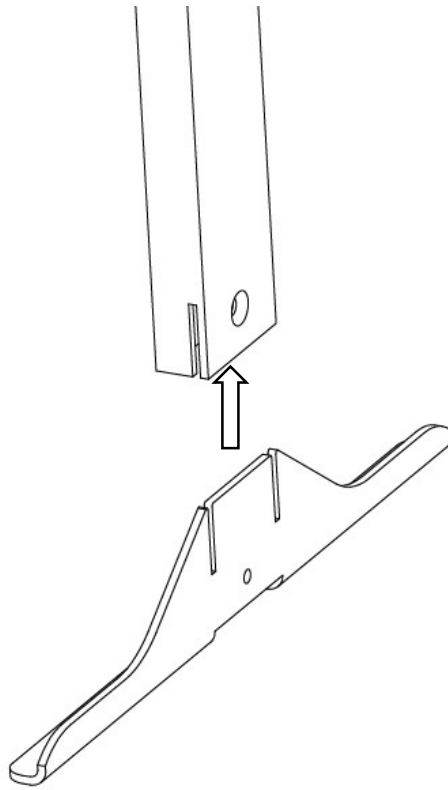

2x (T1 + T2)

7.

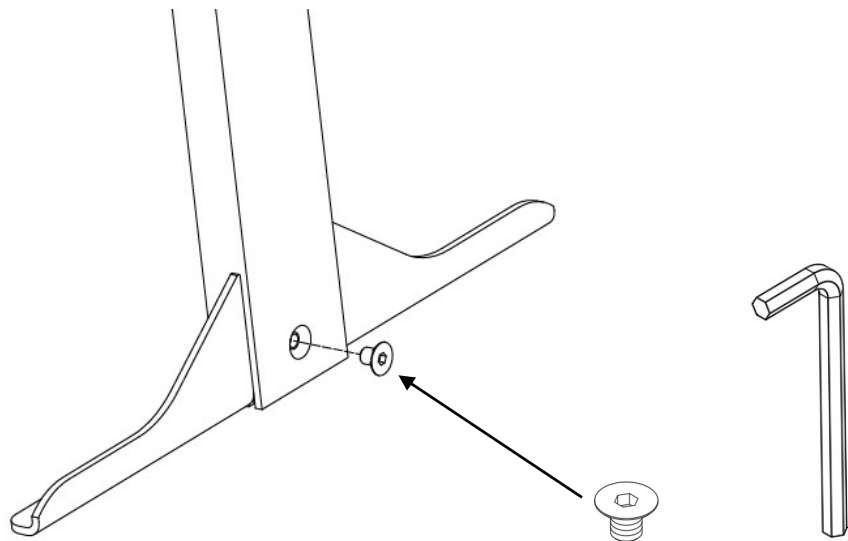

2x

1x (T9) + **1x** (T12)

8.

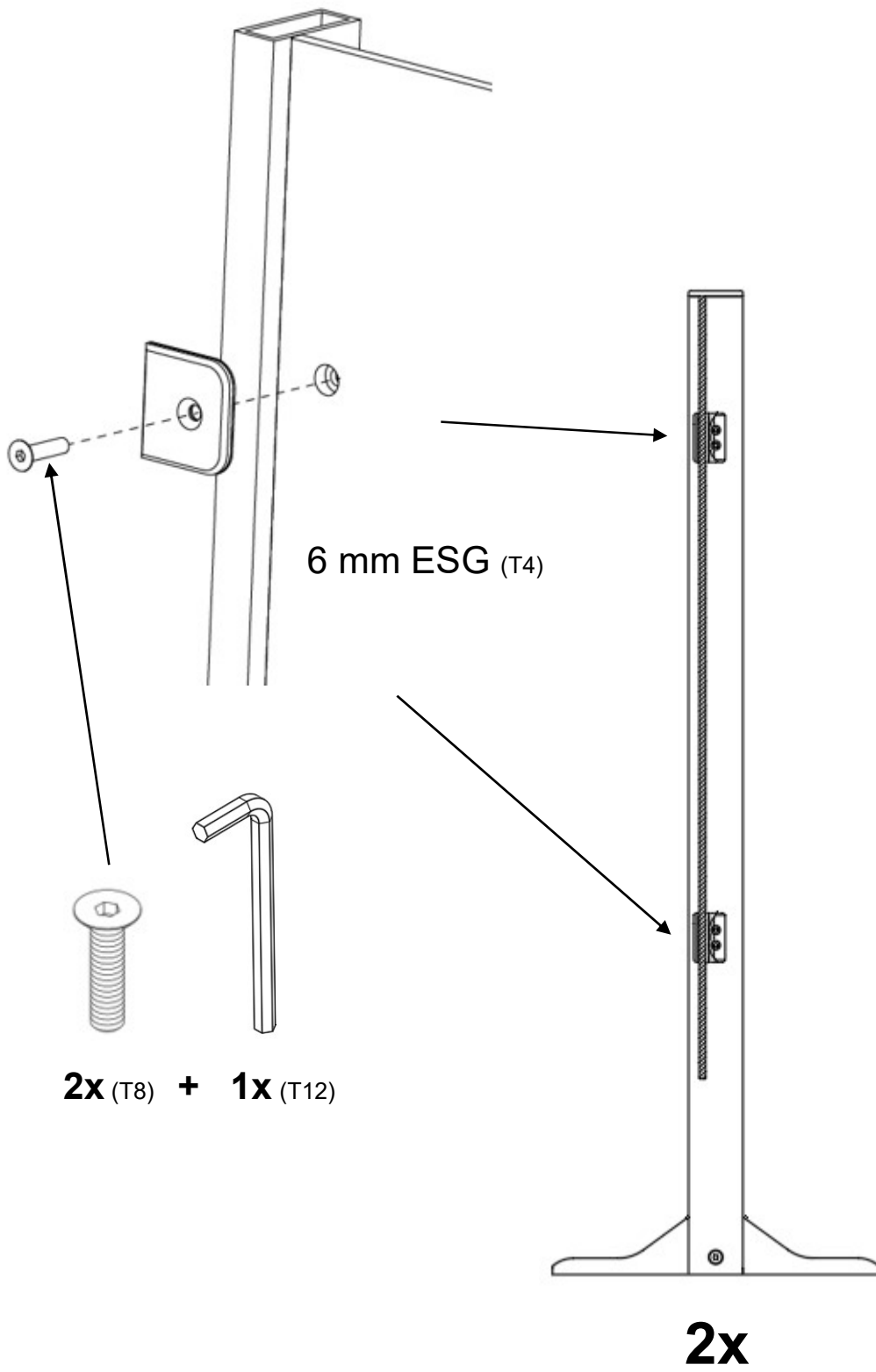

9.

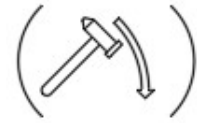
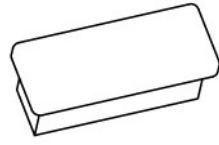

2x (T7)

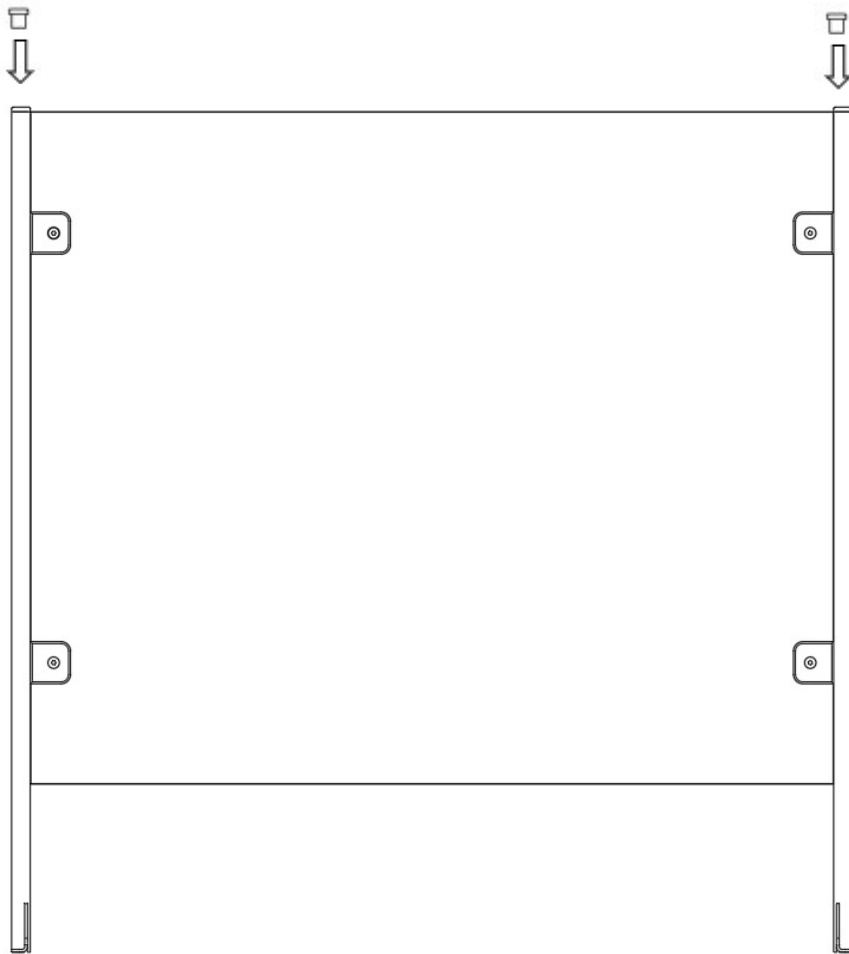

1x

10.

Befestigung:

OPTION 1:

Die „Hygiene-Spuck-Schutzwand“ muss mit dem Trägermaterial verschraubt werden (4 Schrauben pro „Hygiene-Spuck-Schutzwand“, nicht im Lieferumfang enthalten).

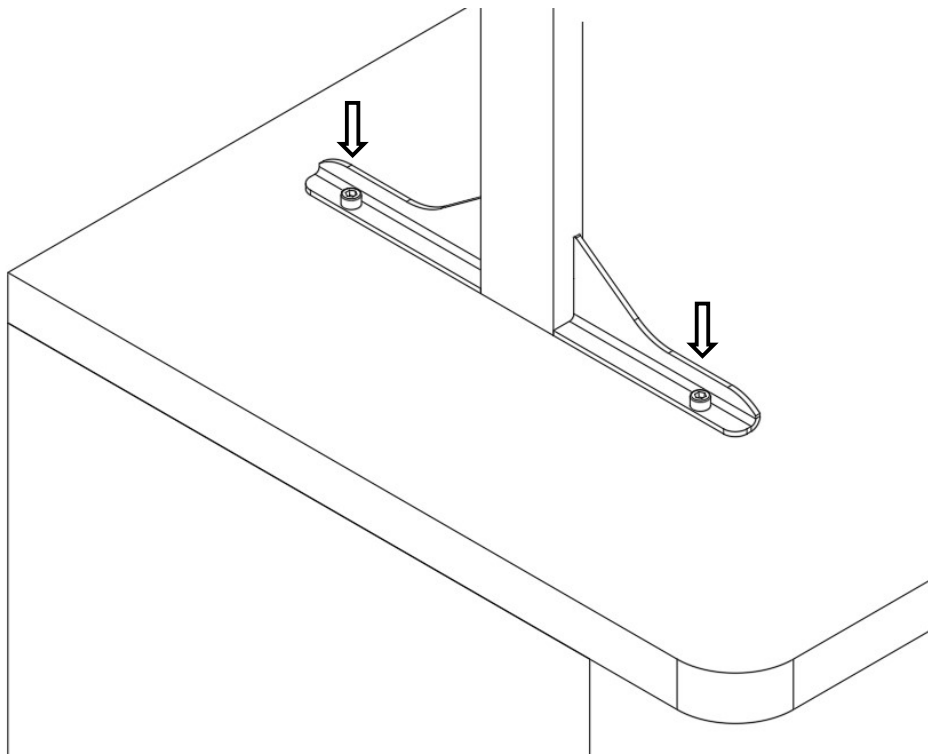

2x

OPTION 2:

Die „Hygiene-Spuck-Schutzwand“ muss mit dem Trägermaterial verklebt werden. Die beiden zu verklebenden Oberflächen müssen hierzu zunächst gesäubert, gereinigt und mit Primer vorbereitet werden, anschließend kann der Klebestreifen flächig aufgebracht werden. Für die korrekte Anwendung des Klebers und des Primers folgen Sie bitte den Anweisungen des Herstellers. Wir empfehlen folgenden Kleber und Primer:

- tesa® ACX plus (7065)
- tesa® Adhesion Promoter UNIVERSAL (60150)

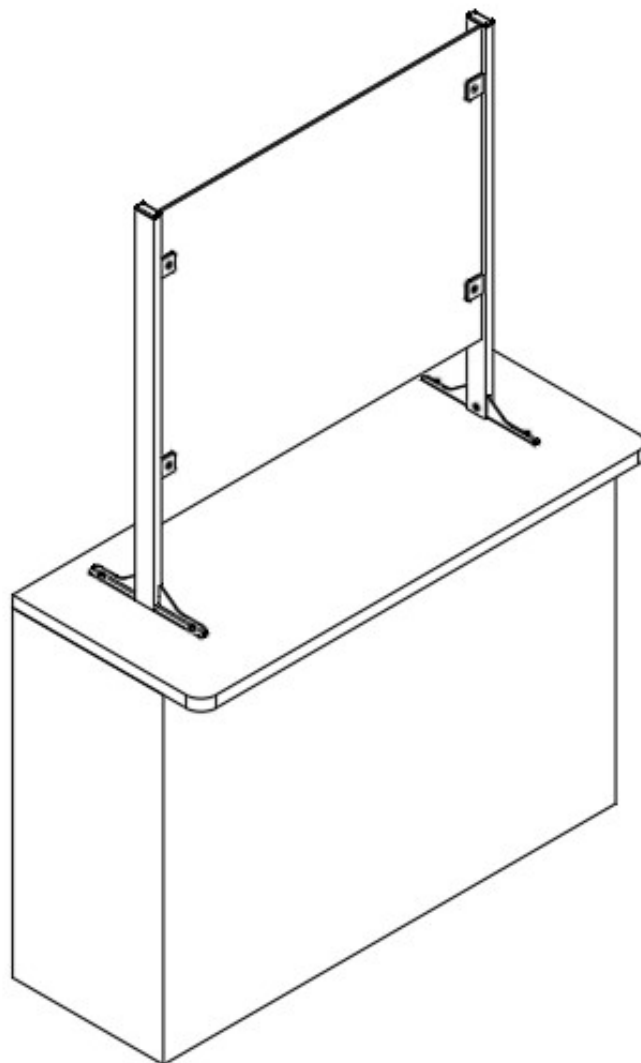

HAHN Lamellenfenster GmbH

Hafenstraße 5-7

63811 Stockstadt

Tel.: +49 (0) 6027 4162 20

Fax: +49 (0) 6027 4162 99

info@hahn-lamellenfenster.de

www.hahn-lamellenfenster.de