

Technical description:

- Pneumatic cylinder with 40mm piston diameter
- Piston rod diameter 12mm, stainless steel 1.4104 with eye bolt Ø8
- Cylinder components made of aluminium
- Piston rod both end positions locked (double locking)
- Maximum locking force 6500N
- Recommended operating pressure 6-10bar
- Theoretical lifting force at 6bar ca. 750N
- Maximum static operating pressure 60bar
- Air supply at the lower end via bottom swivel mounting BSA2
- Ambient temperature range -25 - +60°C, to VdS 2159 for 2hrs up to +110°C
- Air quality: The compressed air must be filtered by an usual filterelement at least.
- VdS approval no.: G508001

Ordering example:

PUDV 40/12-165-KV21-8-BSA2

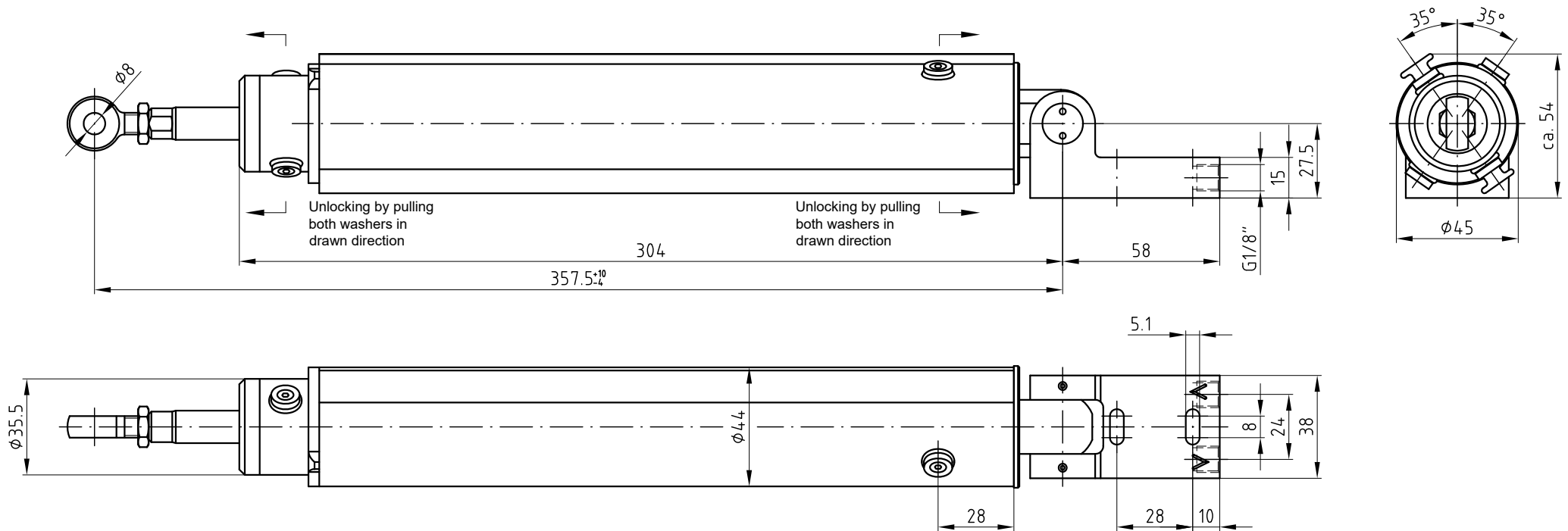
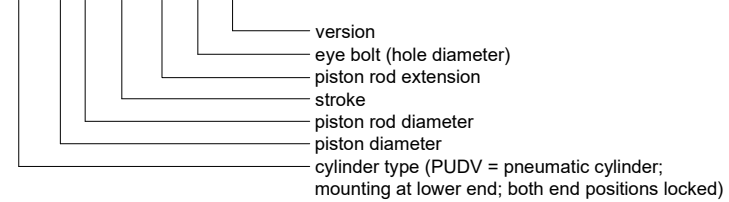

Diese Zeichnung ist Eigentum der
 Fa. Grasl GmbH A-3454 Reidling, EuropastraÙ 1
 Die Weiterverwendung oder Vervielfälti-
 gung ohne unser schriftliches Einver-
 ständnis ist verboten!





GRASL Pneumatic-Mechanik GmbH A-3454 Reidling EuropastraÙe 1		FreimaÙtoleranz nach DIN 7168:		MaÙstab: 1:1	Werkstoff:
				ID - Nr.:	
				Bezeichnung:	
				Data sheet PUDV 40/12-165-KV21-8-BSA2	
				Zeichnung Nr.:	Blatt
				02.003.DAT.05.00-E	BL.
Zus.	Änderung	Datum	Name	(Urspr.)	(Ers.f.)
					(Ers.d.)

Technical Instructions

Pneumatic cylinder, double-acting, typ P

Please read through these technical instructions carefully and fully.
Work on these devices must only be carried out by qualified personnel.

Meaning of the symbols

-  **Safety instructions** must be observed!
The disregarding of these instructions can lead to personal injury and / or material damage.
-  **Advice**, the non-compliance with these instructions or the technical data shall lead to the loss of rights under guarantee.
-  **Correct**,
This is how it should be done.
-  **Incorrect**,
This is how it should not be done.

Correct and proper use

The cylinder serve the purpose of opening and closing NSHEV devices, such as windows, blinds and vents in the roof area (no free access for system-external persons). The producer of the NSHEV is responsible for the implementation of EN 12101. For all other applications the compatibility and thus the security can not be guaranteed. On the application of voltage, a movement command is activated.

If the drives are installed below an installation height of 2,5m to the floor, or to the next access level, appropriate devices must be fitted so that people are not endangered (crushing and trapping hazards). Apply the Directives, Rules and Standards intended for this purpose, such as, for example, EN 14351 and ASR A1.6. Do not allow children to play with the device or its control and / or control devices, including window controls.

Technical details

The cylinder are suitable for compressed air (filtered through filter element), or for CO₂ from suitable CO₂ bottles.

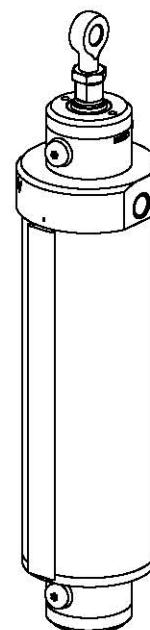



picture 1: pneumatic cylinder

-  The technical data and permissible loads on the cylinders must be observed.

The drives must only be used in normal atmospheric conditions. In the case of atypical ambient atmosphere (for example, SO₂-, saline atmosphere), please consult.

Installation

-  Handle the drive only with appropriate PPE (eg cut resistant gloves).
-  Prepare the installation space of the cylinder in such a way that there is no risk of crushing (e.g.: providing protection plates).
-  The cylinder mounting must be designed according to the cylinder forces.

The following must be observed before mounting:

-  Check the completeness of the scope of supply. Check cylinder and piston rod for transport damages.

Ensure that the cylinder can freely pivot in the whole of the stroke range and cannot come into contact with parts of the building.

Before fixing the cylinders to the coupling bracket, mounting brackets or other fixing elements, the possible installation dimensions of the relevant drive designs must be taken from the data sheets.

Mount the cylinders on the appropriate fixing elements. It must be ensured that the mountings are secured by means of appropriate safety devices (siehe picture 2).

-  In order to prevent the screwing out of the eyebolt, the lock nut must be tightened (siehe picture 2).

Pay attention to the aligned installation of coupling brackets, mounting brackets or other fixing elements. Lateral forces must be avoided (siehe picture 2).

-  It must be ensured that the cylinders can always reach their end position, otherwise locking, possibly existing internal locking, is not guaranteed. Use the eyebolt (adjustment range) for adjustment. Check the setting in the retracted condition by means of marking on the piston rod end (see picture 3).

Setting the closing force with which the NSHEV is driven into the seal by adjusting the eye bolt or other piston rod suspensions. (NRWG must be tightly closed all around).

When installing the console, make sure that the pivot axis of the cylinder is parallel to the hinge axis (see picture 4).

Cylinder mounting

Mount the cylinder with the fixing material (picture 5 / *1).

- a ... coupling bracket
- b ... coupling bracket bolts
- c ... eyebolt
- d ... lock nut
- e ... washer
- f ... split pin
- g ... bearing pins
- h ... mounting bracket

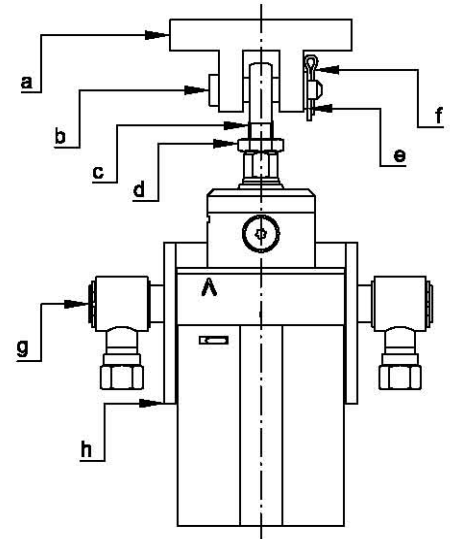

picture 2: fixing elements

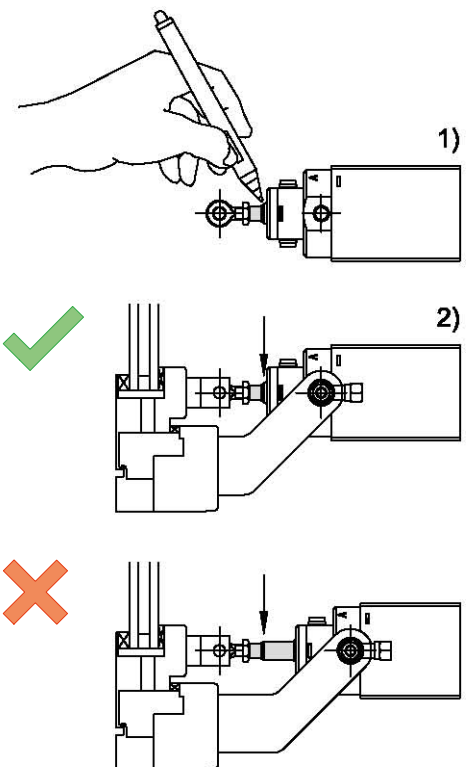

picture 3: end position

i When screwing in the fittings, position them straight to the hole. Otherwise, a perfect function can not be guaranteed. Tightening torque $20\text{-}30\text{Nm}$.

i Regard direction of arrow according to picture 5 / * 2!

Piston rod mounting

Mount the piston rod over the appropriate mounting version in the provided mounting.

Eye bolt

i Regard the adjustment range! To prevent the eye bolt from being unscrewed, the nut must be countered. (picture 6 / * 1).

Spring locking bolt

i The spring locking bolt must be locked again, as in the delivery condition. (picture 6 / *2).

Installation

Before commissioning, the following must be regarded:

! Check if the cylinder can pass through its full stroke without collision with other parts of the system. In this case, it is also important to take care of deformations at maximum load and maximum pressure.

i Check the function of the end position locking (if existing).

Normal operation

! The cylinder has no internal protection against crushing.

Locking (if existing)

• The cyl. is in the extended end position, pressureless, locked.

• Unlocking:

Pneumatic: Apply pressure to the compressed air supply.

Manual: Pull on the unlocking device (picture 7).

! Release the locking under load will cause the window, louver or flap to move. This can lead to serious injury.

! A force-supporting operation by external influences, e.g. overhead installation, gas pressure-/spring-support and the like, is not permitted. There is a risk of failing the locking.

a ...Scharnierachse

b ...Schwenkachse

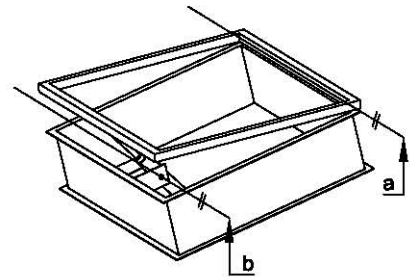

picture 4: installation

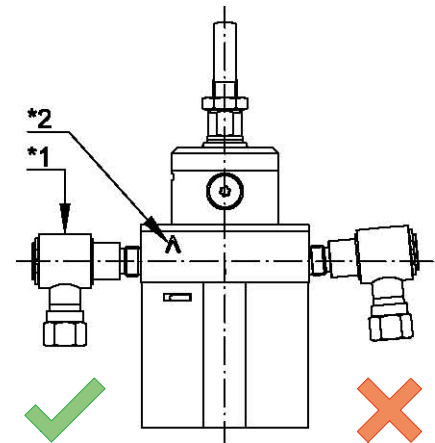

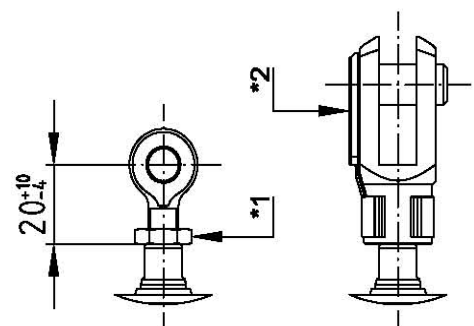

picture 5: direction of arrow



picture 6: piston rod mounting

Maintenance/dismantling/fault finding

 Stop the control of the cylinder and depressurize the cylinder to prevent unwanted movements due to external control/move commands. As the cylinder depressurizes, the cylinder may move (check memory). Therefore, the cylinder or the device should be blocked.

 Make sure that the working area is clear of obstacles and that there are no persons in the danger zone.

 When re-connect, observe possible movements by pending travel commands.

The following points must be checked:

- Check unlocking screws for rust-freeness.
- Check the seal ring of the unlocking screw for wear, damage and sealing to the housing.
- Check the piston rod for rust-freeness, damage and cleanliness (clean if necessary).
- Check wiper for piston rod for wear and sealing to piston rod.
- Check all cylinder parts for tightness (it is absolutely necessary to check the cylinder in any lifting position).
- Check for dustiness (clean if necessary).
- During the course of the annual maintenance, an inspection of the mechanical fixings must be carried out. Where necessary, these must be re-tightened using customary tools.
- Inspection of the structural conditions for changes with regard to the requirements listed in the point, Installation.
- The equipment should be checked for imbalance, signs of wear or damage to cables, springs and fasteners.
- Perform a manual functional test.

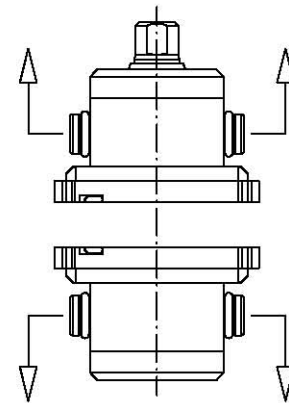

picture 7: locking

 The maintenance must be carried out once per year by a specialist trained for the purpose.

 The cylinder must not be opened. The unauthorized opening of the cylinder shall lead to the exclusion of liability and loss of warranty. After opening the housing, the drive is no longer safe to operate and must not be used anymore.

Disposal

The cylinder consists of the following materials: rubber compound (NBR), plastic (POM), aluminum (AlCuMgPb, AlMgSi0.5), steel (1.4104).

 The cylinder must be disposed of in accordance with national regulations.